

SWISSLOG ACCESSORIES

AUTOMATIC GUIDED VEHICLE (AGV) BULK MATERIAL CARTS



The TransCar automatic guided vehicle (AGV) system serves multiple hospital departments using specialized carts for the distribution of bulk food, medical and surgical supplies, pharmaceuticals, patient food, soiled dishes, clean and soiled linens, trash, and regulated medical waste.

Swisslog supplies payload-specific carts to meet the unique needs of each department. The carts can be enhanced with RFID tags to automatically identify the cart type, input default destinations, and track the activity and timing of individual carts. Automated cart dumping stations are available for trash and linens, as well as an automatic cart washer/dryer; offering a complete integrated logistics system.

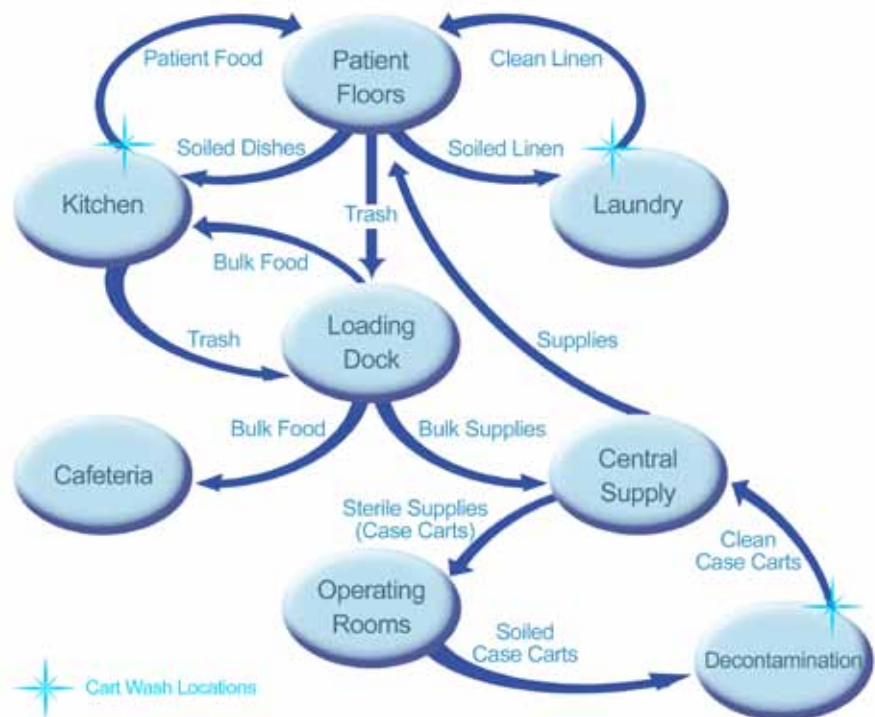

swisslog

AGV Bulk Material Carts

With a wide variety of carts available for departmental uses, AGV systems can increase your return on investment by moving multiple material types 24 hours per day.

Food Carts

Food carts are designed for specific food service systems, allowing the kitchen to deliver meals to patient areas—whether it be room service, hot food tray line or retherm (cook/chill) operations. Food carts are either tandem (1/2 size for transport of 2 at a time) or full size, and can serve dual purpose by returning soiled dishes to the kitchen.



Hot Meal Cart



Tandem Carts (transport 1 or 2)

Supply Carts

Enclosed stainless steel supply carts include adjustable shelving or removable shuttles for transfer onto dollies while inside SPD and OR areas.

Shuttle systems can reduce the quantity of enclosed carts required and increase operational efficiencies. Supply carts are available in either tandem (1/2 size) or full size.



Shuttle System Case Cart



Sterile Supply/Pharmacy Cart

Whether you operate with exchange carts or par level, TransCar can meet the needs of your facility.

Trash and Linen Carts

Bin-forming carts enable highly efficient transport from clean deliveries to soiled returns for linen/laundry and supplies/trash. Shelves support clean materials when en route to clean holding rooms on patient floors. Once empty, the shelves are moved into the side position, forming a bin for the return of soiled materials. Wire lattice or fiberglass bin-forming carts are processed through a cart washer before reuse with clean materials.



Open Style Bin-Forming Cart



Fiberglass Bin-Forming Cart



Mechanized Dumping

Increase automation using a mechanized dumper for trash and/or soiled linen carts.

Dumping Cart (above)

General Purpose Carts

General purpose carts are designed to transport multiple supplies and materials.



Flatbed Cart

Automatic Guided Vehicle (AGV) Bulk Material Carts



Existing Carts

Existing carts can often be reused by removing their casters and placing the cart body onto a transfer carriage (substructure) which contains the necessary position magnets and dimensional space for automatic interface with the robotic vehicles.

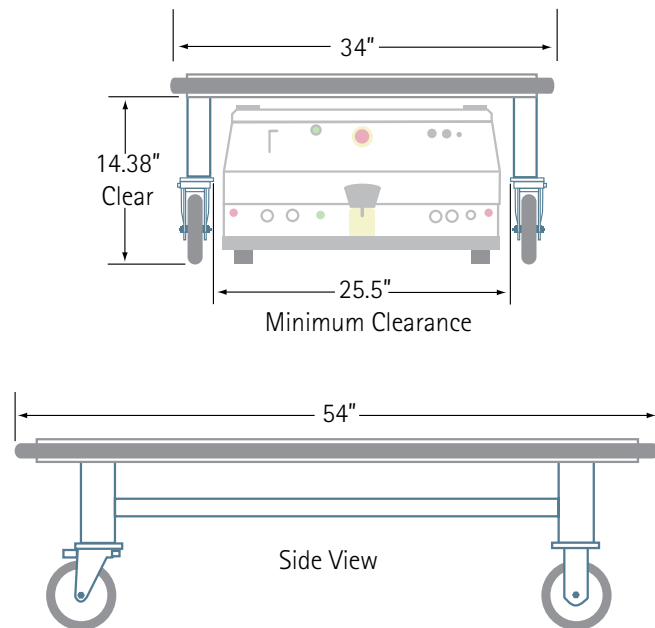

Cart Washers/Dryers

Swisslog's AGV system can be fully integrated with tow-through cart washers/dryers. The AGVs deliver carts prepared for washing, and pick them up after drying.



Due to ongoing improvement programs, Swisslog reserves the right of production or design change without notice or obligation.

For More Information in North America:

Swisslog Healthcare Solutions
Email: healthcare@swisslog.com
USA: 800.764.0300
Canada: 877.294.2831 | 905.629.2400

©2010 Swisslog
CM# AGV-200

WWW.SWISSLOG.COM